

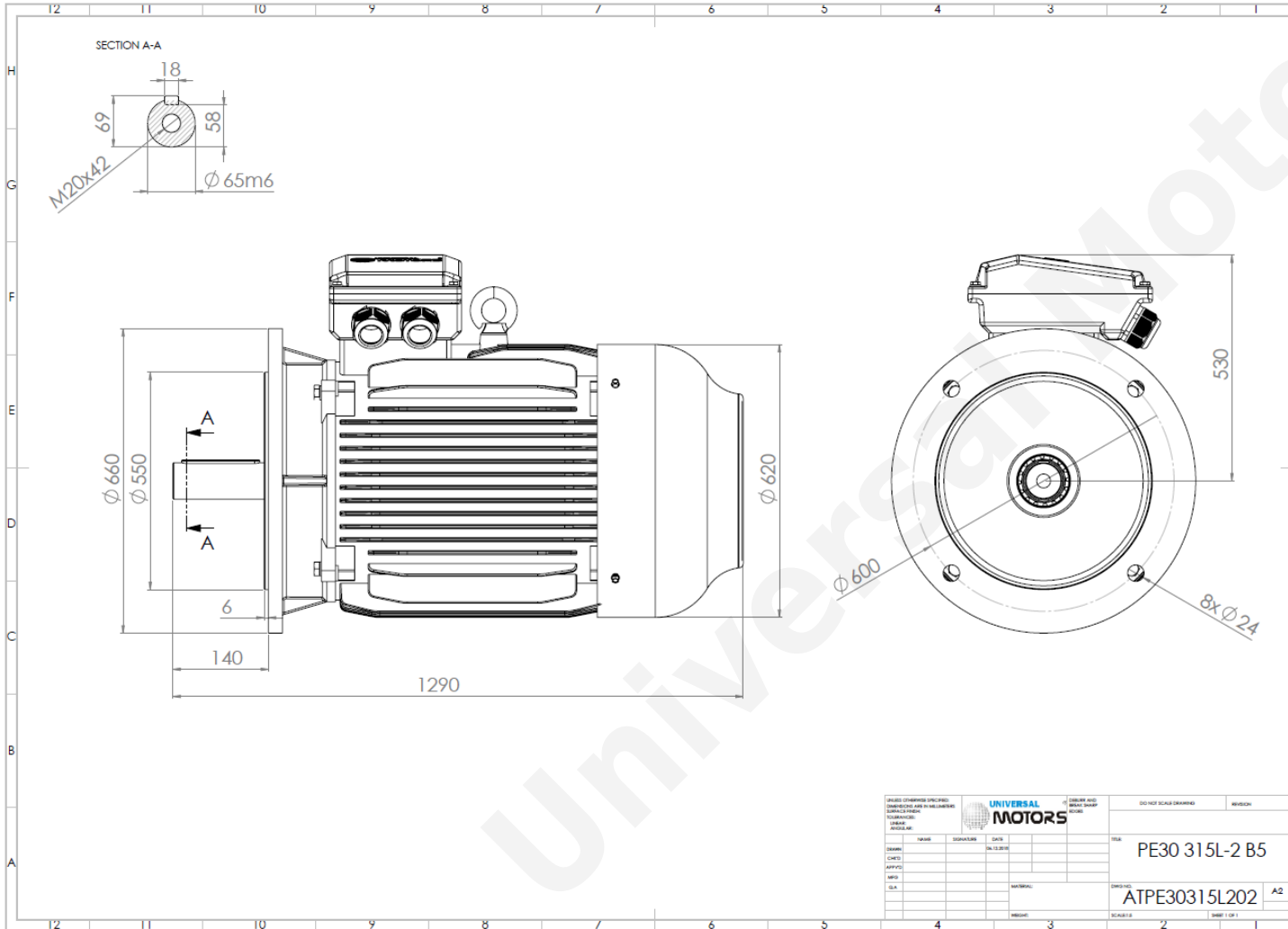

TECHNICAL DATA

Three Phase Electric Motors - Cast Iron Frame
 PE30 315 L2 2 IE3
 200 kW / 270 Cv
 2980 RPM



Motor type:	PE30 315 L2 2 IE3
Output:	200 kW / 270 Cv
Speed (min ⁻¹):	2980 RPM
Frequency:	50 Hz
Voltage:	400 V
Current:	331.0 A
Power factor (Cos Ø):	0.91
Poles:	2
Insulation class:	F
Temperature rise Class:	B
Efficiency 50%:	94.9 %
Efficiency 75%:	95.8 %
Efficiency 100%:	95.9 %
Torque:	641 N.m
Tstarting/Tnominal:	1.8
Istarting/Inominal:	7.2
Tmaximum/Tnominal:	2.2
Noise:	92 Db(A)
Weight:	1095 Kg
Bearing DE:	6319 C3
Bearing NDE:	6319 C3

Regime - S1

Altitude - 1000m

Environment Temperature - 40°C

CONTACTS:

UNIVERSAL MOTORS Tel: +351 252 299 080
 Rua de São Brás,745 Fax: +351 252 299 089
 4480-782 VILA DO CONDE Mail: geral@universalmotors.pt

* References applied only in the UK